

John Deere
1400 Series G.B.P.P.
Parts List & Mounting Instructions

Jodale • Perry

Printed: 2005/04

John Deere 1420, 1435, 1445 Mounting Instructions

Standard Parts List

Qty	Description	Photo
L&R	Rear Cab Brackets	
2	Cab Lift Brackets (1" Tube)	
18"	O-rubber, Clip-on, 180°	
12.5 LF	O-rubber, Clip-on, 90°	

NOTE: All references to left and right are taken from the operator's point of view when he/she is sitting in the driver's seat.

John Deere 1420, 1435, 1445 Mounting Instructions

Standard Bolts List

Qty	Description
4	Bolt, Hex, 5/8" x 2", Grade 8, Yellow Dichrome
2	Bolt, Hex, 1/2" x 3", Grade 8, Yellow Dichrome
2	Bolt, Hex, 1/2" x 4 1/2", Grade 8, Yellow Dichrome
4	Nut, Hex, 5/8", Grade 8, Yellow Dichrome
4	Nut, Hex, 1/2", Grade 8, Yellow Dichrome
4	Washer, Lock, 5/8", Plated
4	Washer, Lock, 1/2", Plated
2	Washer, Flat, Rubber, Trimmed 2 sides
2	Washer, Flat, Rubber, Trimmed 1 side
2	Washer, Flat, Steel, 9/16" x 2 1/2" Trimmed 2 sides
2	Washer, Flat, Steel, 9/16" x 2 1/2" Trimmed 1 side
4	Isolator, Rubber, 1/2" x 2 1/2", Black
2	Tube Spacer Lower, 1"OD x 5/8"ID x 11/16"
2	Tube Spacer Upper, 1"OD x 5/8"ID x 5/16"

NOTE: All references to left and right are taken from the operator's point of view when he/she is sitting in the driver's seat.

John Deere 1420, 1435, 1445 Mounting Instructions

NOTE: Use the following torque specifications for all hardware: 1/2" hardware 73 ft-lbs, 3/8" hardware 42 ft-lbs, 5/8" hardware 177 ft-lbs.

1. Prior to cab installation, remove the upper section of the 2-post ROPS guard, remove seat from seat plate.

Figure 1



2. Take the left rear bracket, one short tube spacer, and one long tube spacer and position it onto the left lower 2-post ROPS member. Put the longer tube spacer into the bottom hole of the ROPS, and the shorter tube spacer into the upper ROPS hole and loosely fasten the rear bracket into place using the hardware provided, 5/8" x 2" hex bolts, nuts, and lock washers. Ensure that the washer and nut are on the outside of the machine side for space requirements. Repeat for the right rear bracket, see Figure 1.

3. Locate the tubing crossmember which is located underneath the operator foot platform. Use Figures 2 and 3 as a guide and drill two 9/16" holes through the tubing crossmember and the foot platform.

Figure 2

See attached blueprint



4. Remove the left door and right escape window before proceeding with the following steps. Take the cab lift brackets and bolt them onto the cab frame with the ends sticking away from the frame. Remove the shipping bracket from the rear mounts and prepare to lift the cab with an overhead hoist so that the cab O-rubber can be installed.

5. Take the 90° O-rubber and beginning at the left rear corner, slide the rubber onto the steel panel with the bulb facing down, and work your way forward and around the cab frame until you reach the same point on the right rear corner of the cab. See Figure 4 & 5. You will have to put a separate piece between the front mount plates.

6. Take the 180° O-rubber, and starting where you stopped in the previous step, slide the rubber onto the panel until you reach the panel shown in Figure 10.

NOTE: All references to left and right are taken from the operator's point of view when he/she is sitting in the driver's seat.

John Deere 1420, 1435, 1445 Mounting Instructions

Figure 4



Figure 5

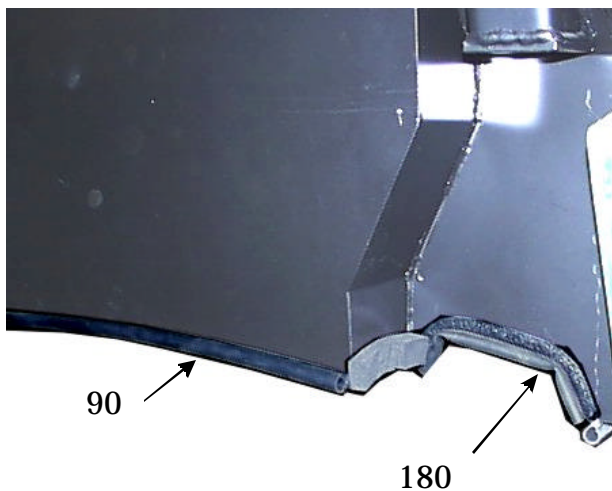
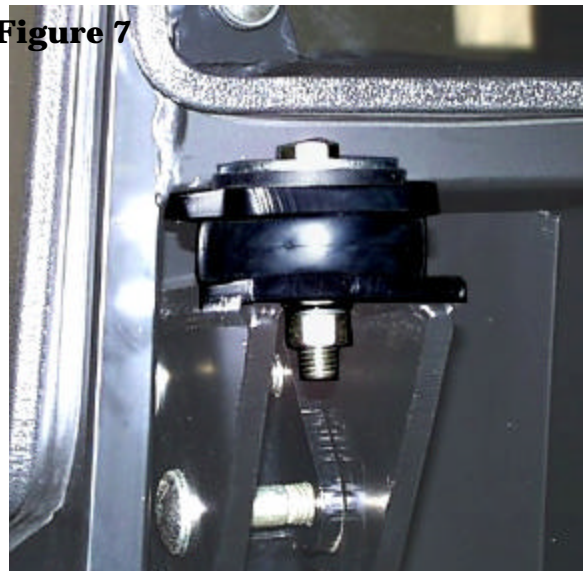

Figure 6

7. From where you left off in the previous step, slide 90° O-rubber onto the rear steel panel and then repeat for the other side. See Figure 6.

8. Move to the lower two post ROPS, and note the rear steel crossmember bolted to the ROPS member. Loosen all four bolts in order to make the installation of the cab easier. Lift the cab over the machine and slowly lower the cab over the rear mounts. Place one rubber isolator over each of the two rear mounts, and over the two holes drilled into the front platform. Once the cab is lowered onto the rear mounts, take one 1/2" x 3" hex bolt, one 9/16" x 2 1/2" steel flat washer (trimmed 2 sides), one 9/16" x 2 1/2" rubber flat washer (trimmed 2 sides), one 1/2" lock washer, and one 1/2" hex nut and loosely fasten each rear mount. Repeat for the front mounts, but use 1/2" x 4 1/2" hex bolts instead and loosely fasten the cab down. The front mounts locate the cab frame front to back, so tighten the two front mounts to the torque spec first, and then the rear mounts next, and finally the rear cab brackets last. See Figure 7.

Figure 7



NOTE: All references to left and right are taken from the operator's point of view when he/she is sitting in the driver's seat.

Revision	Decision	Date

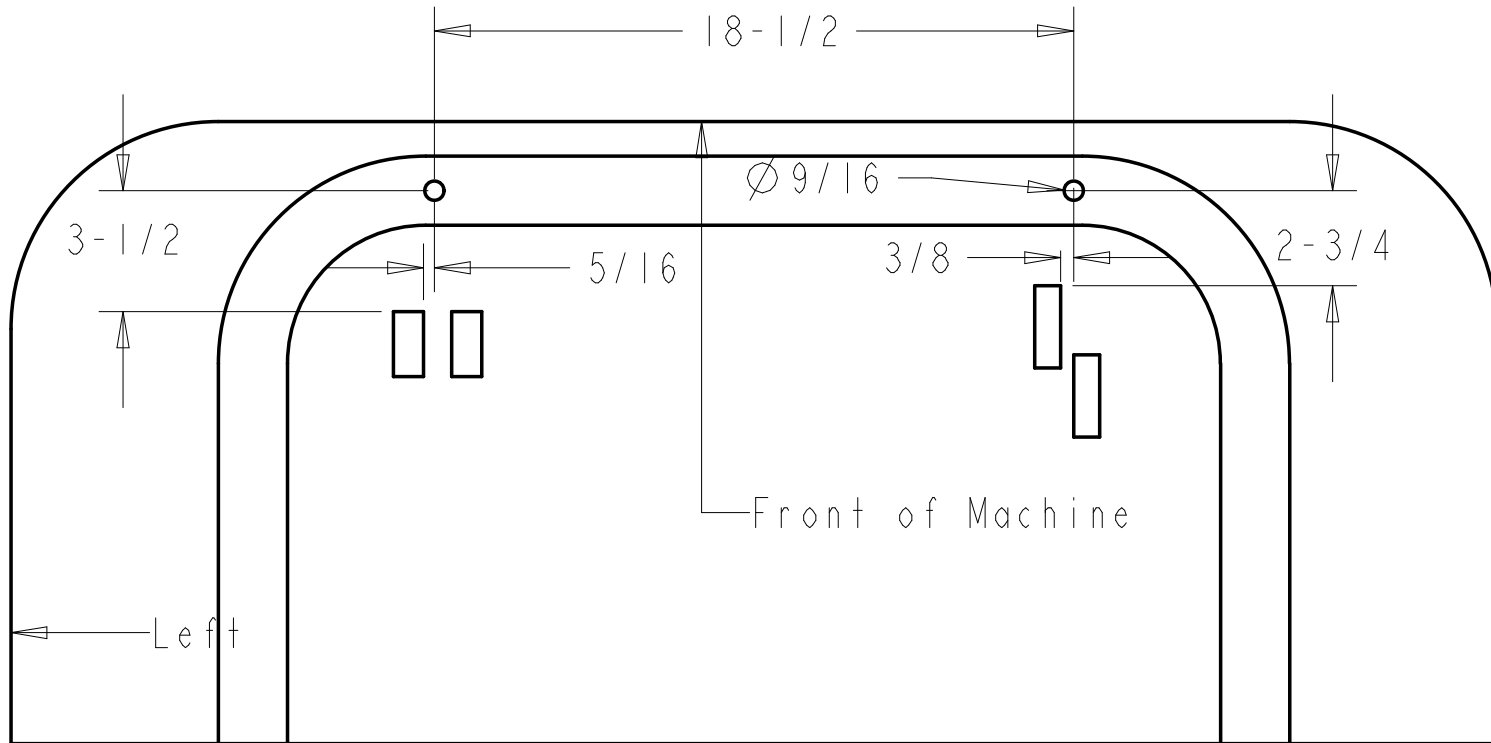

Tolerances:
 Unless otherwise specified
 X.X = $\pm 1/16$ "
 Angular = $\pm 1.0^\circ$

SCALE 0.180

CONFIDENTIALITY NOTICE

This material is property of Jodale Perry Corporation (JDP) or one of its subsidiaries or affiliates and is not to be used by the recipient for any purpose other than the purpose for which it was transmitted. The material remains the property of JDP and shall be returned upon request. The material may not be reproduced or disclosed to third parties without the written consent of JDP

Material		Req'd		JODALE PERRY CORPORATION Box 909, 300 Route 100, Morden MB, Canada			
				Title Front Mount Drill Template			
Drawn By Dave Friesen	Date 2001-05-01	Size A	Part Number	Project John Deere 1400	Rev		
Checked By	Date	Scale	Units Imperial	File Number JDI400PRT0115			